



**EXELTECH**

7317 Jack Newell Blvd North  
Fort Worth, Texas 76118-7100  
817.595.4969 voice, 817.595.1290 fax  
800.886.4683 toll free  
website [www.exeltech.com](http://www.exeltech.com)

- **ULTRA LIGHTWEIGHT**
- **AVAILABLE IN 120, 240 OR 208VAC OUTPUT**
- **12, 24, 48, AND 66VDC INPUT**
- **WEATHER RESISTANT**
- **METERING**
- **2KW, 4KW OR 6KW OUTPUT**



August 2008.  
4KW and 6KW Power Inverters  
931-MILM\*-\*0B



CAGE CODE 00MC3  
NSN 6130-01-492-3067 \* 6KW system

## Table of Contents

Warnings / Cautions/ Notes:	<b><i>page 3</i></b>
Safety/ Health (installation):	<b><i>page 4</i></b>
DC to AC Power Inverter features:	<b><i>page 5</i></b>
Operating Instructions:	<b><i>page 6 - 7</i></b>
System Part Number:	<b><i>page 8</i></b>
Specifications:	<b><i>page 9</i></b>
Mechanical Drawings:	<b><i>page 10 - 11</i></b>

---

Copyright © 2008 Exeltech Inc. All rights reserved. This Document may not be copied, photocopied, reproduced, translated or converted to any electronic or machine-readable form in whole or in part without prior written approval of Exeltech Inc.

Exeltech  
7317 Jack Newell Blvd North  
Fort Worth, Texas 76118-7100

## Warnings / Cautions/ Notes:

**CAUTION:** It is essential to read and understand all Warnings, Cautions, and Notes before any connections are made to the Unit or System. If further assistance is needed call (817) 595-4969 and ask for Customer Service.

**WARNING:** The inverter is designed to operate from a Battery. Performance cannot be guaranteed when a charger or power supply is used without a battery in the circuit.

**WARNING:** Inverter Chassis and Neutral AC output lead must be connected together. The unit must be shipped with this connection. If this connection is removed, it must be provided somewhere else in the system. Either one of the Battery connections should be connected to Chassis to comply with most code requirements.



**CAUTION:** Before any connections are made to the Unit or System, be sure to disconnect the grounded battery terminal. Reconnect this lead when work is finished.

**CAUTION:** Polarity of leads is critical to avoid damage to the unit or system. Check batteries and battery cables for correct polarity and voltage.



**CAUTION:** Observe all National and Local Electric Codes when connecting AC Power Connections. All wiring should be copper and must follow the NEC, local or other codes in effect at the installation, regardless of suggestions in this document.

**CAUTION:** The inverter is a ruggedized piece of electronic equipment. However, gasses emanating from the battery can be corrosive and highly flammable. Therefore, the inverter should be isolated from the battery bank as much as possible.

**CAUTION:** Unit requires 6 inch minimum clearance from each side of the system to provide adequate ventilation.

	 <b>CAUTION</b>
	DIRECT CURRENT VOLTAGE
	POLARITY OF LEADS IS CRITICAL TO AVOID DAMAGE TO THE UNIT OR SYSTEM.
	CHECK BATTERIES AND BATTERY CABLES FOR CORRECT POLARITY AND VOLTAGE.

921-00346-000

	 <b>CAUTION</b>
	HIGH VOLTAGE AC
	CONTACT MAY CAUSE ELECTRIC SHOCK OR BURN OR DEATH.
	TURN OFF AND LOCK-OUT SYSTEM POWER BEFORE SERVICING.

## Safety/ Health: (Installation)

1. The inverter requires adequate ventilation for cooling. With proper cooling the inverter will operate efficiently and meet its published ratings.
2. The inverter should be mounted as close to the battery as possible. Shorter lengths of wire have less resistance, which translates to increased efficiencies.

**DC INPUT CONNECTIONS:** Positive (+) and Negative (-) input terminals are 2- Mechanical Compression Connectors ( Box Type Lug 4/0 - 2AWG ). They are provided under the Front Access Cover. Choose appropriate gauge wire for your specific model and distance from the battery.

1. Disconnect **negative (-)** terminal of the battery and make sure the inverter is OFF.
2. Make DC input connections to the inverter as illustrated.
3. Load AC voltage connection may be hard wired as illustrated.
4. Re-connect **negative (-)** terminal of the battery.



**4KW SINGLE PHASE SYSTEM**



**6KW SINGLE PHASE SYSTEM**



**4KW BI-PHASE SYSTEM**

## DC to AC Power Inverter features

### Features

The inverter is a stand-alone fixed unit with mounting holes in the base for attachment to a flat surface.

### Size

Mechanical dimensions: 4KW - 10 inches High X 11 inches Deep X 18 inches Wide  
6KW - 10 inches High X 14 inches Deep X 21 inches Wide

### Connections

#### Input and Output

Input connections: 2- Mechanical Compression Connectors ( Box Type Lug 4/0 - 2AWG )  
(BATT + and BATT - )

Output connections: 4 pole connector strip. 4KW unit up to 8 ga.; 6KW unit up to 6ga.

Ground connection: Ground chassis connector up to 6ga.

#### Controls

“On” / “Off” switch, Battery voltage test.

#### Electrical input

The inverter operates on DC power.

#### Electrical Output

The inverter is capable of converting DC to AC, 120Vac (4KW and 6KW systems), 120/240Vac (4KW system) or 120/208Vac (6KW system). True sine wave.

### Power

The inverter has an output capacity of 4,000 Watts (4KW system) or 6,000 Watts (6KW system) during continuous operation in ambient air temperatures. At extreme temperatures of -25°C to +50°C, the power output will not drop more than 660W (4KW system) and 1,000 Watts (6KW system).

### Protective Features

#### Low voltage

The inverter provides a low voltage light to warn the operators of steady-state input voltage drops below minimum voltage level Vdc. To allow for momentary voltage drops, the low-voltage sensing circuit incorporates a delay of 10 seconds. The inverter has a manual reset after shutting down for low voltage, and draws no current until the reset is activated. The inverter draws no current after being manually switched off.

#### Thermal Overload

The inverter provides automatic high temperature shut down capability when the internal temperature exceeds safe limits.

#### Electrical Overload

The inverter has an output overload protection circuit.

#### Status Indication

The inverter has Light-emitting Diodes (LED) to indicate inverter power, low input voltage, overload, and high temperature.

#### Moisture

The inverter circuit boards are conformal coated.

- ON – Green LED - will be illuminated anytime the inverter is ON, it will stay illuminated even if overtemp or overload warnings are engaged until reset by the operator.
- TEMP – Solid Red LED - Will illuminate as the inverter temperature is approaching its maximum safe operating temperature.
- Flashing Red LED - The TEMP LED will flash when the inverter has exceeded its maximum safe operating temperature and will shutdown and has shutdown. The inverter will reset automatically after the unit has sufficiently cooled to ensure safe operation. Fans will continue to run during this period.
- OVLD - Solid Red LED - Will illuminate when the inverter has detected an excessive power drain. This typically occurs when starting a external device and should only last a few seconds.
- Flashing Red LED - The OVLD LED will begin to flash when the excessive power drain has occurred for too long. The inverter will shutdown to prevent any damage to the inverter or any external devices and the inverter must be shutoff and restarted.
- ON – this button will turn the inverter “ON”.
- OFF – This button will turn the inverter “OFF”.
- Note: “Reset” is accomplished by: PRESS “OFF” THEN PRESS “ON”

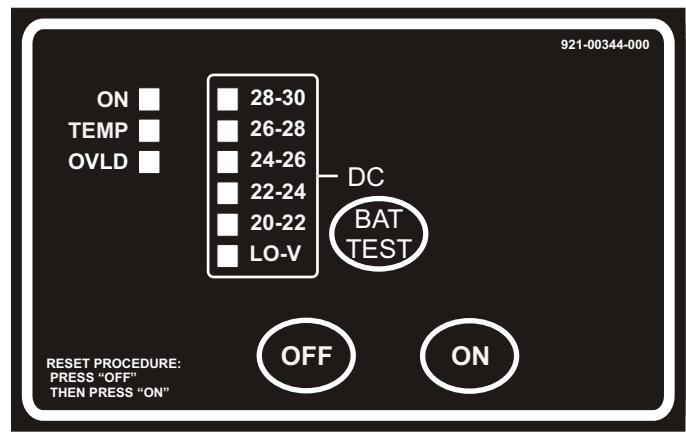

\*

Voltmeter – Indicates the Voltage of the battery as seen by the inverter.

Nominal voltage	Voltage	LED “ON”	Color
30	29.5 - 30.5	28 - 30	RED
29	28.5 - 29.5	28 - 30	GREEN
28	27.5 - 28.5	26 - 28 , 28 - 30	GREEN
27	26.5 - 27.5	26 - 28	GREEN
26	25.5 - 26.5	24 - 26 , 26 - 28	GREEN
25	24.5 - 25.5	24 - 26	GREEN
24	23.5 - 24.5	22 - 24 , 24 - 26	GREEN
23	22.5 - 23.5	22 - 24	GREEN
22	21.5 - 22.5	20 - 22 , 22 - 24	GREEN
21	20.5 - 21.5	20 - 22	GREEN
20	< 21	LO-V	RED

\* Representative of a 24Vdc version.

## Maintenance and Servicing Instructions (preventive and corrective):

Make sure ventilation is not obstructed.

Periodically check torque on DC connections [recommended 75 lbs-in max.]  
and AC Connections [4KW recommended 7 lbs-in max.];  
[6KW recommended 21 lbs-in max. ] (every 6 month).

## Storage:

Storage temperature -40°C to +75°C  
5 to 95% humidity non-condensing.

## Packaging:

If you have to return unit for repair, send it back in the original packing or equivalent to protect it from shipping damage.

## NOTES:

# XO/MI SERIES SYSTEM PART NUMBER

## EXELTECH XO/MI SERIES MODEL NUMBER

STEP # 1 Model number always starts with XO or MI

STEP # 2 Cage assembly

1	2	4	6	7	9
19" XO	23" XO	4KW MI	6KW MI	7" XO	9" XO

STEP # 3 Configuration

1 phase	2 phase	3 phase
B	E	F

STEP # 4 Enter three asterisks ( \* )

STEP # 5 Character assigned by EXELTECH to represent changes or revisions levels.

STEP # 6 To designate power level, enter the number of modules required. ( \* if none used)

STEP # 7 Enter from the following character code  
Q = 100Vac, M = 120Vac, O = 230Vac

STEP # 8 To designate input voltage, enter the single character from the VDC voltage chart below:

VDC INPUT VOLTAGE CHART						
DC VOLTS	12	24	32	48	66	108
DESIGNATION	1	2	B	4	E	I

STEP # 9 Output frequency is designated by using the first number of the frequency. 5 for 50Hz, 6 for 60Hz, 4 for 400Hz

STEP # 10 Character assigned by EXELTECH to represent revision level of Power Modules.

STEP # 11 For options, enter two digit code. If no option, enter (00).

Example: XO9B\*\*\*-3ME6-01  
MI6E\*\*\*-3M26-00



7317 Jack Newell Blvd North  
Fort Worth, Texas 76118-7100  
817.595.4969 voice, 817.595.1290 fax  
800.886.4683 toll free  
website www.exeltech.com

# POWER INVERTER SPECIFICATIONS

## OUTPUT POWER

CONTINUOUS POWER	SURGE POWER	NO LOAD POWER	OUTPUT VOLTAGE	OUTPUT CURRENT per KW	WEIGHT LBS.
4000W	8000W	24W	1 or 2	8.3 A	32
6000W	12000W	35W	1 or 3	8.3 A	42

1 Single phase 120Vac +/- 2%  
 2 Bi-phase 120/240Vac +/- 2%  
 3 3 phase 120/208Vac +/- 2%

## PROTECTION CIRCUITRY

Over Voltage:	Shutoff at maximum input voltage, per input conditions.
Under Voltage:	Shutoff at minimum input voltage, per input table
Thermal:	105 C internal temperature.
Output Short:	Unit shuts off: electronically limited. Manual reset required.

## INPUT

MODEL VOLTAGE	MINIMUM (TYPICAL)	SYSTEM (TYPICAL)	MAXIMUM (TYPICAL)	TYPICAL EFFICIENCY @ FULL POWER	PEAK EFFICIENCY @ 1/2 POWER
24V	21V	27.6V	30V	> 88%	> 90%
48V	42V	55.2V	60V	> 88%	> 90%
66V	57.8V	75.9V	82.5V	> 88%	> 90%

## ENVIRONMENTAL

Temperature:	-25°C to +25°C full power, derated -17% @ 50°C then 20% per 10°C above 50°C.
Humidity:	5 to 95% non-condensing
Cooling:	Thermostatically controlled variable speed forced air
Finish:	Powder coated
Warranty:	Two years parts and labor.

## GENERAL

CONDITIONS	MINIMUM	TYPICAL	MAXIMUM
WAVEFORM	-	SINUSOIDAL	-
LINE REGULATION	-	.1%	2%
LOAD REGULATION	-	.3%	2%
DISTORTION	-	1.5%	2%
FREQUENCY*	-.1%	60Hz	+.1%

## MECHANICAL

Case size:
4KW
10 inches High
11 inches Deep
18 inches Wide
Weight: 32 lbs.
6KW
10 inches High
14 inches Deep
21 inches Wide
Weight: 42 lbs.



7317 Jack Newell Blvd North  
 Fort Worth, Texas 76118-7100  
 817.595.4969 voice, 817.595.1290 fax  
 800.886.4683 toll free  
 website www.exeltech.com

Made in the USA

# 4KW MECHANICAL DRAWINGS

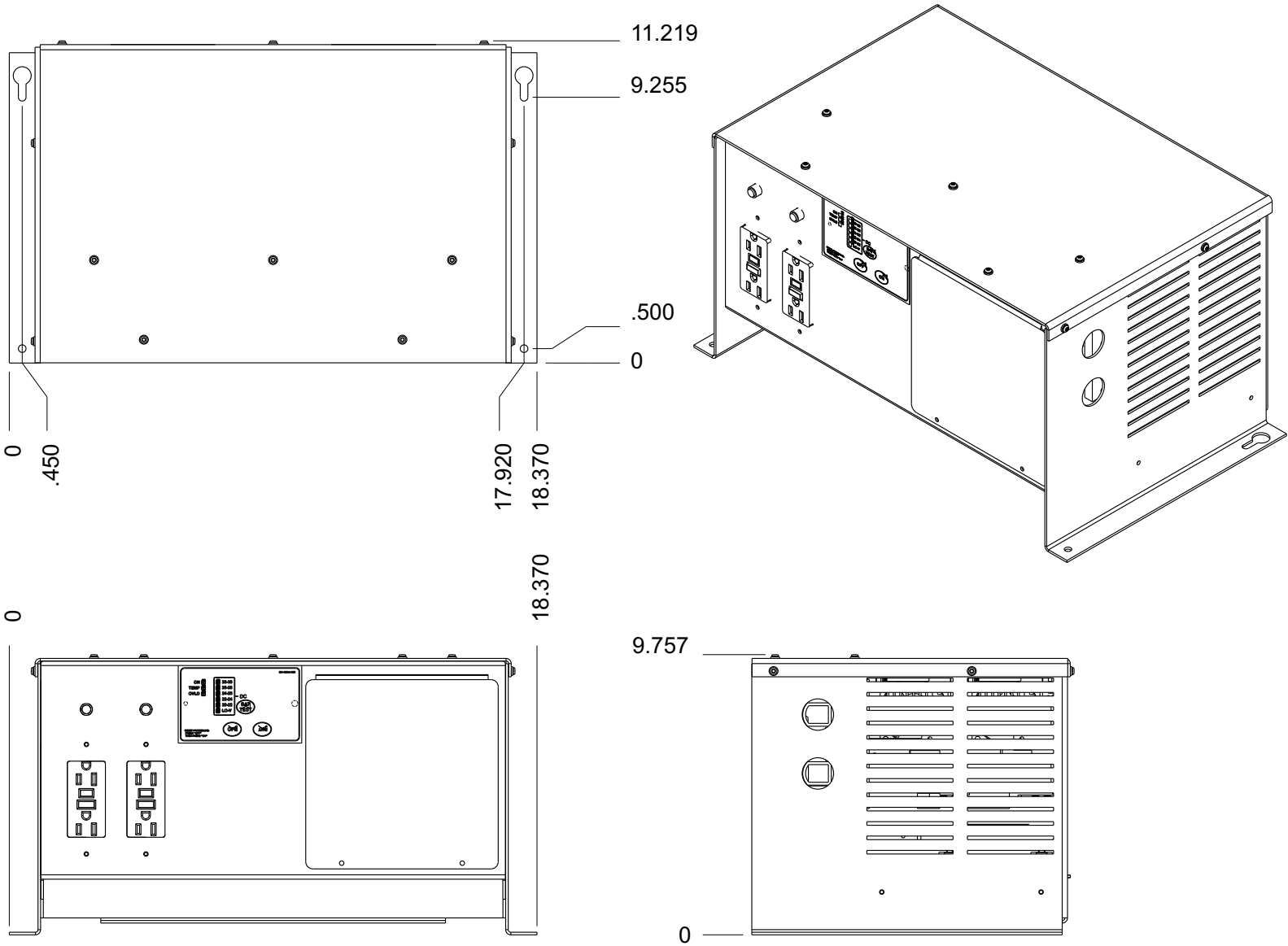

7317 Jack Newell Blvd North  
Fort Worth, Texas 76118-7100  
817.595.4969 voice, 817.595.1290 fax  
800.886.4683 toll free  
website [www.exeltech.com](http://www.exeltech.com)

*Made in the USA*

# 6KW MECHANICAL DRAWINGS

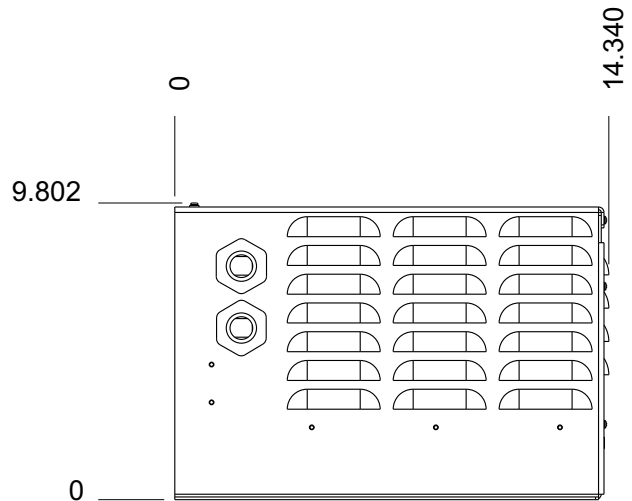
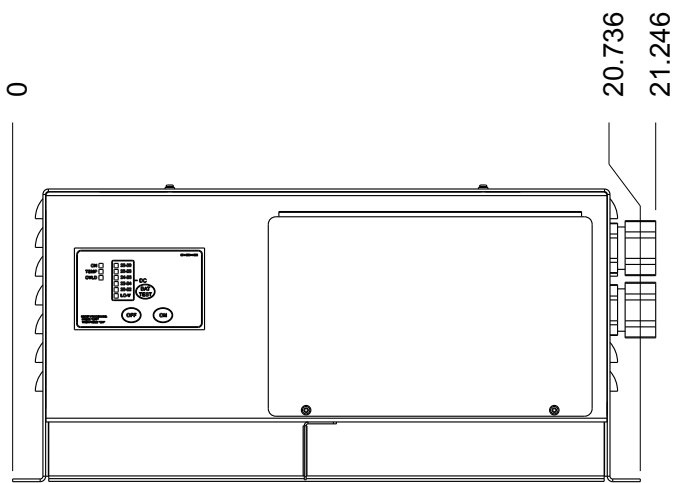
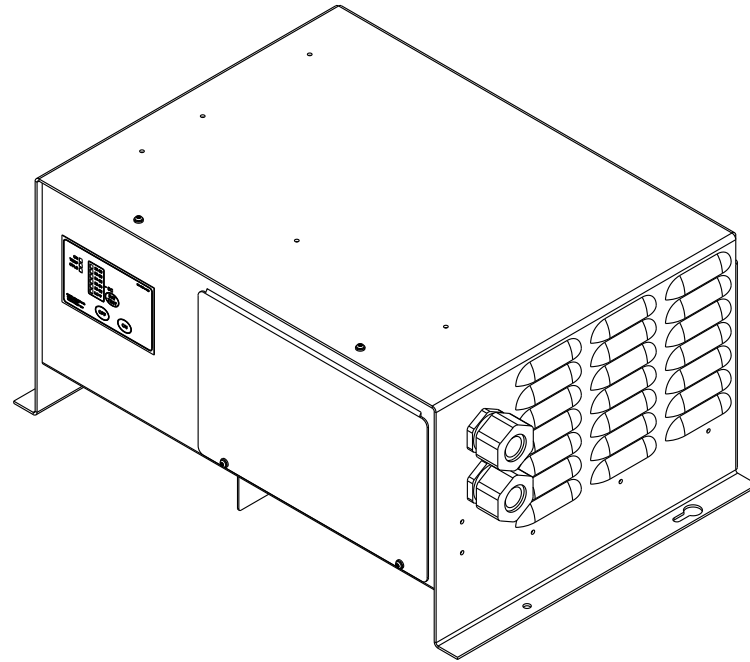
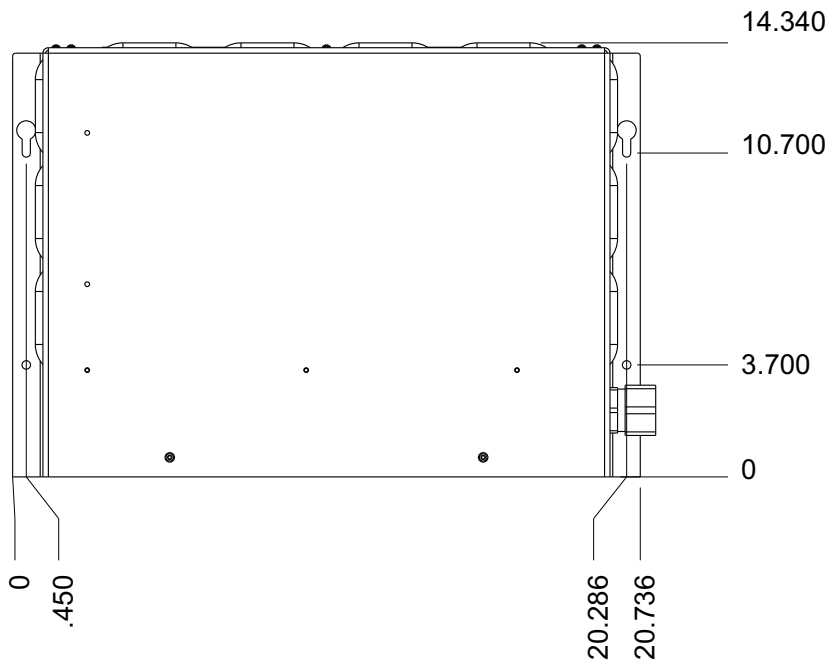

7317 Jack Newell Blvd North  
Fort Worth, Texas 76118-7100  
817.595.4969 voice, 817.595.1290 fax  
800.886.4683 toll free  
website [www.exeltech.com](http://www.exeltech.com)